

## Compact Semiconductor Deep UV Laser

**AIMPICO** compact DPSS laser systems deliver narrow-linewidth, diffraction-limited output across visible and near-infrared wavelengths — engineered for laboratory, clinical, and OEM environments where beam quality, coherence, and long-term power stability are essential.

Built on diode-pumped solid-state technology, AIMPICO DPSS deep UV lasers produce a near TEM<sub>00</sub> beam with polarisation ratios exceeding 100:1. The all-solid-state architecture requires no gas handling, no electrode replacement, and no periodic realignment, delivering a maintenance-free platform rated for over 10,000 hours of continuous operation. Active closed-loop power stabilisation maintains output within  $\pm 1\%$  RMS across the full operating temperature range, with the laser source, drive electronics, and thermal management integrated into a single compact enclosure.



## Applications

- Flow cytometry
- Fluorescence microscopy
- Cell sorting
- OEM instrument
- Advanced research
- Spectroscopy

## Key Feature Highlights

• <b>High Polarization</b>	Defined polarization state for spectroscopy and advanced research applications.
• <b>Stable Output (<math>\pm 1\%</math> RMS)</b>	Active closed-loop control ensures consistent power across the full operating range
• <b>All Solid-State, Maintenance-Free Design</b>	No gas handling, no electrode replacement, no realignment — > 10,000-hour operational lifetime
• <b>Compact, Integration-Ready Platform</b>	Laser source and drive electronics in a single enclosure with TTL and analogue modulation
• <b>Long Operational Lifetime</b>	Semiconductor gain medium with no consumables, no gas fill, and no electrodes — operate without scheduled maintenance interventions

# Technical Specification

---

## OPTICAL PARAMETERS

Center Wavelength	261 nm $\pm$ 1 nm
Operating Mode	Continuous Wave
Output Power	100 – 1500 mW
Power Stability (rms, 4 hours $\pm$ 3°C)	< 1%
Transverse Mode	Near TEM <sub>00</sub>
Beam Divergence (full angle)	< 3.0 mrad
Beam Diameter at the aperture (1/e <sup>2</sup> )	< 3.0 mm
Polarization Ratio	> 50:1 (100:1 optional), vertical (horizontal optional)

## ELECTRICAL PARAMETERS

Operating Voltage	12 V / 25 A
Modulation Options	DC-1kHz, TTL/Analog optional

## MECHANICAL PARAMETERS

Dimensions	370.0(L) $\times$ 236.0(W) $\times$ 137.0(H) mm <sup>3</sup>
Weight	17.8 kg
Beam Height from Base Plate	94.0 mm

## ENVIRONMENTAL

Operating Temperature	10 – 35 °C
Cooling Method	Water Cooled; WC-I
Start Up Time	< 10 min
Expected Lifetime	> 10,000 hours

---

# Mechanical Drawings

## Laser Head (Driver integrated)

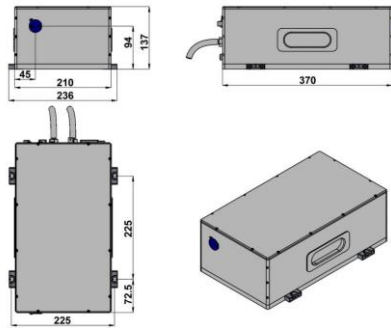

370(L) × 236(W) × 137(H) mm<sup>3</sup>, 17.8kg

## Compatible Power Supply (100 – 240VAC<sup>1</sup>)

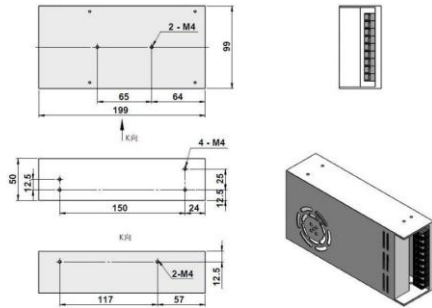

199(L) × 99(W) × 50(H) mm<sup>3</sup>, 1.0kg

## Water Chiller (WC-I<sup>2</sup>)

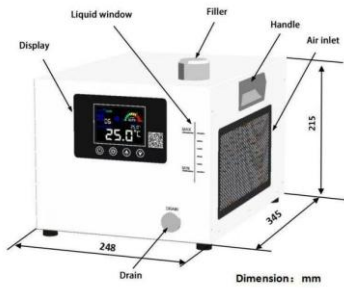

345(L) × 248(W) × 215(H) mm<sup>3</sup>, 10.5kg

## Product Certifications



<sup>1</sup>: Optional; sold separately.

<sup>2</sup>: Sold separately.

