

Precision Photonics

Cutting Edge Engineering at the Speed of Light



Compact Semiconductor Blue Laser

AIMPICO compact DPSS laser systems deliver narrow-linewidth, diffraction-limited output across visible and near-infrared wavelengths — engineered for laboratory, clinical, and OEM environments where beam quality, coherence, and long-term power stability are essential.

Built on diode-pumped solid-state technology, AIMPICO DPSS lasers produce a highly coherent TEM₀₀ beam with polarisation ratios exceeding 100:1 and spectral linewidth below 0.1 nm. The all-solid-state architecture requires no gas handling, no electrode replacement, and no periodic realignment, delivering a maintenance-free platform rated for over 10,000 hours of continuous operation. Active closed-loop power stabilisation maintains output within $\pm 1\%$ RMS across the full operating temperature range, with the laser source, drive electronics, and thermal management integrated into a single compact enclosure.



Applications

- Medical diagnostics & treatment
- OEM instrument
- Advanced research
- Spectroscopy

Key Feature Highlights

• TEM₀₀ mode with Superb Beam Quality	Diffraction-limited output for precise fiber coupling, spectrometer slit filling, and confocal microscopy
• Narrow Linewidth & High Polarization	High spectral purity and defined polarization state for spectroscopy, interferometry, holography and scattering experiments
• Stable Output ($\pm 1\%$ RMS)	Active closed-loop control ensures consistent power across the full operating range
• All Solid-State, Maintenance-Free Design	No gas handling, no electrode replacement, no realignment — > 10,000-hour operational lifetime
• Compact, Integration-Ready Platform	Laser source, drive electronics, and thermal management in a single enclosure with TTL and analogue modulation



Technical Specification

OPTICAL PARAMETERS

Center Wavelength	473 nm ± 1 nm
Operating Mode	Continuous Wave
Output Power	50 – 300mW
Power Stability (rms, 4 hours±3°C)	< 1%
Transverse Mode	TEM ₀₀
Beam Quality (M ²)	< 1.2
Beam Divergence (full angle)	< 1.5 mrad
Beam Diameter at the aperture (1/e ²)	< 1.0 mm
Polarization Ratio	> 100:1, vertical (horizontal optional)
Pointing stability (over 2 hours after warm-up and ±3°C)	< 50 μrad
Pointing stability over temperature	< 8 μrad/°C

ELECTRICAL PARAMETERS

Power Consumption	15 (typical), < 25 W (40 °C)
Modulation Options	DC-1kHz, 1kHz-10kHz, 10kHz-30kHz optional; TTL/Analog optional
Compatible Power Supply (100-240VAC)	LPS-IV/LPS-V/LPS-VI/LPS-OEM-II

MECHANICAL PARAMETERS

Dimensions	142.5(L) × 60(W) × 50(H) mm ³
Weight	1.0 kg
Beam Height from Base Plate	27.4 mm

ENVIRONMENTAL

Operating Temperature	10 – 35 °C
Laser Warmup Time	< 5 min
Expected Lifetime	> 10,000 hours

Mechanical Drawings

Laser Head¹

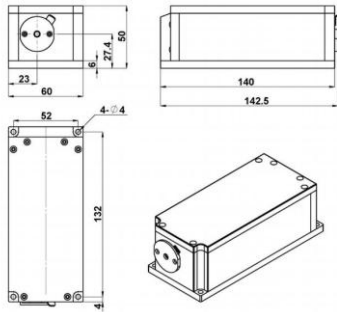

142.5 (L) × 60(W) × 50(H) mm³, 1.0kg

Compatible Power Supply (LPS-IV²)



276.6(L) × 145(W) × 103.6(H) mm³, 2.3kg

Compatible Power Supply (LPS-V³)

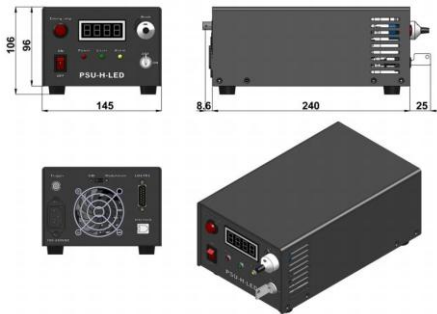

273.6(L) × 145(W) × 106(H) mm³, 2.3kg

Compatible Power Supply (LPS-VI³)

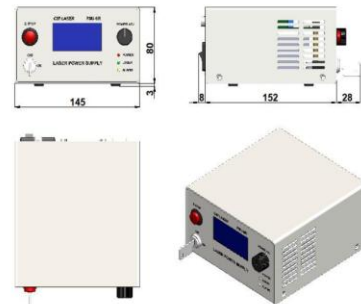

188(L) × 145(W) × 83(H) mm³, 1.2kg

Compatible Power Supply (LPS-OEM-II³)

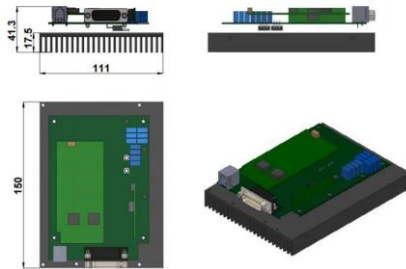

150(L) × 111(W) × 41.3(H) mm³, 0.8kg

Heat Sink (HS-IV⁴)

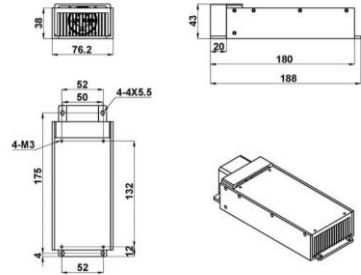

188(L) × 76.2(W) × 43(H) mm³, 0.65kg

Product Certifications



¹: Laser head needs to be used with a heat sink with good heat dissipation

^{2,3,4}: Sold separately.

²: Fixed output power.

³: Output power adjustable 10-100%.

