

# Precision Photonics

Cutting Edge Engineering at the Speed of Light



## Compact Semiconductor Near IR Laser

**AIMPICO** compact DPSS laser systems deliver narrow-linewidth, diffraction-limited output across visible and near-infrared wavelengths — engineered for laboratory, clinical, and OEM environments where beam quality, coherence, and long-term power stability are essential.

Built on diode-pumped solid-state technology, AIMPICO DPSS lasers produce a highly coherent TEM<sub>00</sub> beam with polarisation ratios exceeding 100:1 and spectral linewidth below 0.1 nm. The all-solid-state architecture requires no gas handling, no electrode replacement, and no periodic realignment, delivering a maintenance-free platform rated for over 10,000 hours of continuous operation. Active closed-loop power stabilisation maintains output within  $\pm 1\%$  RMS across the full operating temperature range, with the laser source, drive electronics, and thermal management integrated into a single compact enclosure.



## Applications

- Analytical sensing
- OEM instrument
- Telecommunication
- Advanced research
- Spectroscopy

## Key Feature Highlights

• <b>TEM<sub>00</sub> mode with Superb Beam Quality</b>	Diffraction-limited output for precise fiber coupling, spectrometer slit filling, and confocal microscopy
• <b>Narrow Linewidth &amp; High Polarization</b>	High spectral purity and defined polarization state for spectroscopy, interferometry, holography and scattering experiments
• <b>Stable Output (<math>\pm 1\%</math> RMS)</b>	Active closed-loop control ensures consistent power across the full operating range
• <b>All Solid-State, Maintenance-Free Design</b>	No gas handling, no electrode replacement, no realignment — > 10,000-hour operational lifetime
• <b>Compact, Integration-Ready Platform</b>	Laser source, drive electronics, and thermal management in a single enclosure with TTL and analogue modulation



# Technical Specification

## OPTICAL PARAMETERS

Center Wavelength	1,064 nm $\pm$ 1 nm
Operating Mode	Continuous Wave
Output Power	3,000 – 4,000 mW
Power Stability (rms, 4 hours $\pm$ 3°C)	< 1%
Transverse Mode	TEM <sub>00</sub>
Beam Quality (M <sup>2</sup> )	< 1.5
Beam Divergence (full angle)	< 1.5 mrad
Beam Diameter at the aperture (1/e <sup>2</sup> )	< 1.0 mm
Polarization Ratio	> 100:1, horizontal (vertical optional)
Pointing stability (over 2 hours after warm-up and $\pm$ 3°C)	< 50 $\mu$ rad

## ELECTRICAL PARAMETERS

Power Consumption	15 (typical), < 25 W (40 °C) or 12V / 25A
Modulation Options	DC-1kHz, 1kHz-10kHz, 10kHz-30kHz optional; TTL/Analog optional
Compatible Power Supply (100-240VAC)	LPS-IV/LPS-V/LPS-VI

## MECHANICAL PARAMETERS

Dimensions	160(L) $\times$ 60(W) $\times$ 50(H) mm <sup>3</sup>
Weight	0.9 kg
Beam Height from Base Plate	27.4 mm

## ENVIRONMENTAL

Operating Temperature	10 – 35 °C
Laser Warmup Time	< 5 min
Expected Lifetime	> 10,000 hours

# Mechanical Drawings

## Laser Head<sup>1</sup>

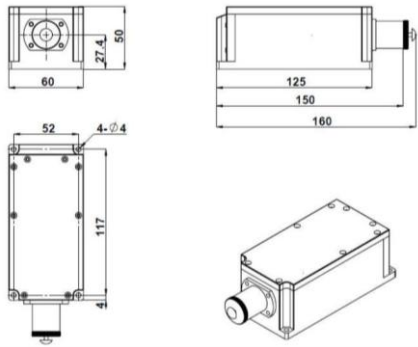

160(L) × 60(W) × 50(H) mm<sup>3</sup>, 0.9kg

## Compatible Power Supply (LPS-IV<sup>2</sup>)



276.6(L) × 145(W) × 103.6(H) mm<sup>3</sup>, 2.3kg

## Compatible Power Supply (LPS-V<sup>3</sup>)

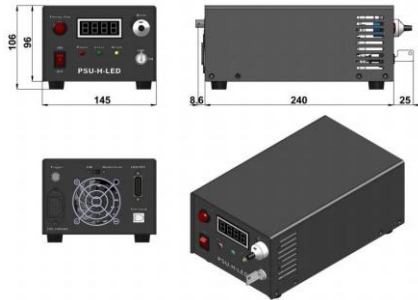

273.6(L) × 145(W) × 106(H) mm<sup>3</sup>, 2.3kg

## Compatible Power Supply (LPS-VI<sup>3</sup>)

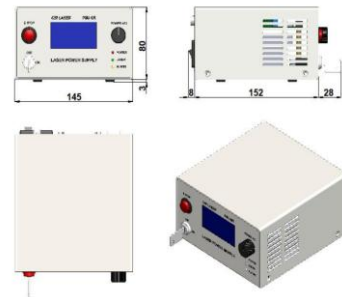

188(L) × 145(W) × 83(H) mm<sup>3</sup>, 1.2kg

## Heat Sink (HS-IV<sup>4</sup>)

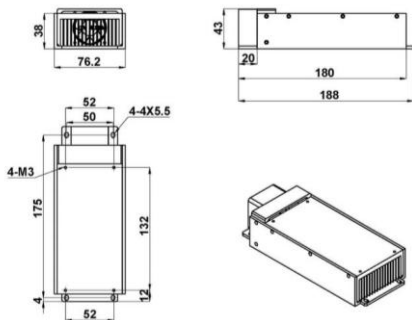

188(L) × 76.2(W) × 43(H) mm<sup>3</sup>, 0.65kg

## Product Certifications



<sup>1</sup>: Laser head needs to be used with a heat sink with good heat dissipation

<sup>2,3</sup>: Sold separately.

<sup>2</sup>: Fixed output power.

<sup>3</sup>: Output power adjustable 10-100%.

<sup>4</sup>: Optional; sold separately.

