

Precision Photonics

Cutting Edge Engineering at the Speed of Light



Compact Semiconductor Red Laser

AIMPICO compact diode laser systems deliver stable, high-quality coherent output across ultraviolet, visible, and near-infrared wavelengths — engineered for laboratory, clinical, and OEM environments where wavelength accuracy, power stability, and long-term reliability are essential.

Built on direct-emission semiconductor technology, AIMPICO lasers require no optical pumping, harmonic conversion, or consumables, offering exceptional wall-plug efficiency and a significantly simplified thermal footprint compared to gas or lamp-pumped alternatives. The laser source, drive electronics, and thermal management are integrated into a single compact platform, with active closed-loop stabilization maintaining output power within $\pm 1\%$ RMS across the full operating temperature range.



Applications

- Life science
- Biophotonics
- Analytical sensing
- Spectroscopy
- Laser light show

Key Feature Highlights

• Compact, Integration-Ready Design	Fits standard optical breadboards and cage systems; Compact design enables direct drop-in to instrument assemblies
• Stable Output ($\pm 1\%$ RMS)	Active closed-loop control ensures consistent power across the full operating range
• 30 kHz TTL/Analog Modulation	Hardware-level synchronization with cameras, lock-in amplifiers, and instrument timing systems
• Efficient Thermal Management	Low thermal load and passive heat dissipation reduce the need for active cooling, simplifying optical table layouts
• Long Operational Lifetime	Semiconductor gain medium with no consumables, no gas fill, and no electrodes — operate without scheduled maintenance interventions



Technical Specification

OPTICAL PARAMETERS

Center Wavelength	635 nm ± 10 nm
Operating Mode	Continuous Wave
Output Power	1 – 1,000 mW
Power Stability (rms, 4 hours±3°C)	< 1%
Transverse Mode	Multimode
Beam Divergence (full angle)	< 3.0 mrad
Beam Diameter at the aperture (1/e ²)	~ 5.0 mm x 8.0 mm
Polarization Ratio	> 50:1 (> 100:1 optional)

ELECTRICAL PARAMETERS

Power Supply	(85-240VAC)	LPS-I/LPS-II (modulation frequency range 1Hz – 100kHz)
	(100-240VAC)	LPS-III (modulation frequency range 30kHz – 100kHz)
Modulation Options	1Hz – 1kHz, 1kHz-10kHz, 10kHz-30kHz, 30kHz-100kHz optional; TTL/analog optional	

MECHANICAL PARAMETERS

Dimensions	146(L) × 73(W) × 46.2(H) mm ³
Weight	0.7 kg
Cooling Method	Conduction
Beam Height from Base Plate	24.8 mm

ENVIRONMENTAL

Operating Temperature	10 – 35 °C
Laser Warmup Time	< 5 min
Expected Lifetime	> 10,000 hours

Mechanical Drawings

Laser Head

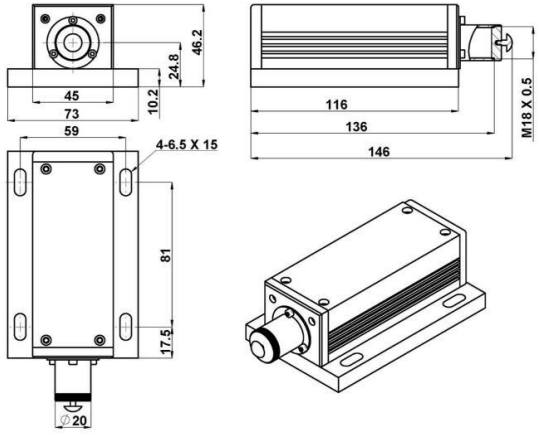

146 (L)×73(W)×46.2 (H) mm³, 0.7kg

Compatible Power Supply (LPS-III¹)

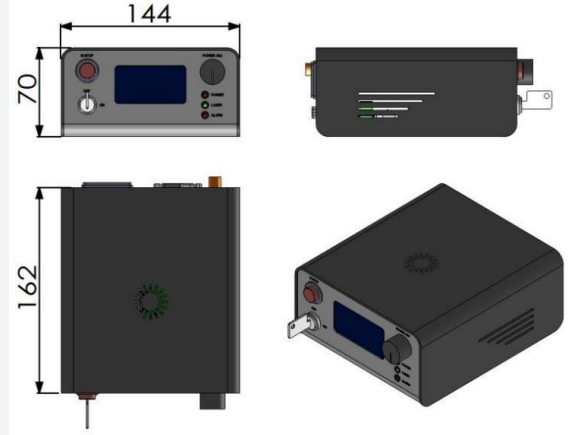

162(L)×144(W)×70(H) mm³, 1.0kg

Compatible Power Supply (LPS-II²)

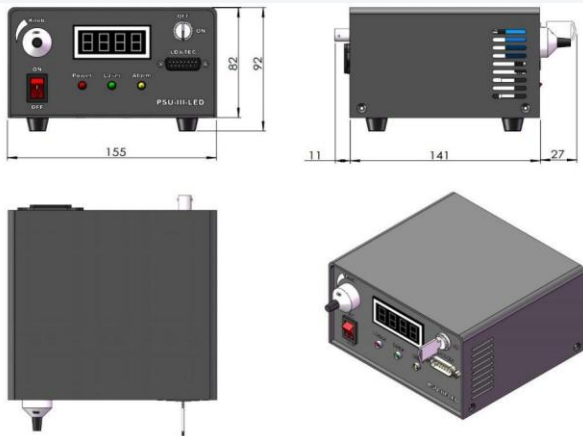

188.6(L)×155(W)×92(H) mm³, 1.5kg

Compatible Power Supply (LPS-I³)

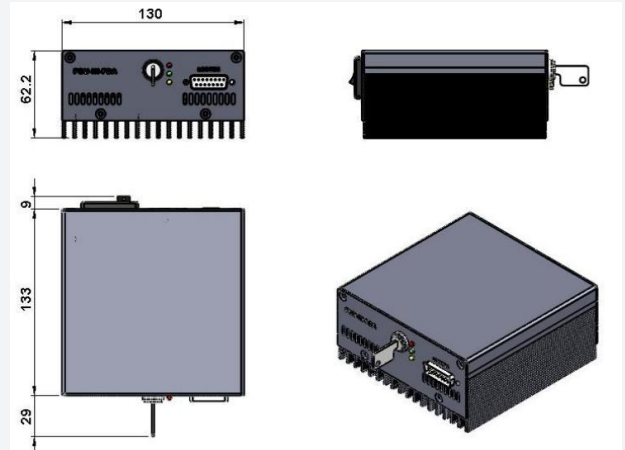

171(L)×130(W)×62.2(H) mm³, 1.2kg

Product Certifications



1,2,3: Sold separately



Toronto, ON, Canada



sales@aimpico.com