

# Precision Photonics

Cutting Edge Engineering at the Speed of Light



## Compact Semiconductor Blue Laser

**AIMPICO** compact diode laser systems deliver stable, high-quality coherent output across ultraviolet, visible, and near-infrared wavelengths — engineered for laboratory, clinical, and OEM environments where wavelength accuracy, power stability, and long-term reliability are essential.

Built on direct-emission semiconductor technology, AIMPICO lasers require no optical pumping, harmonic conversion, or consumables, offering exceptional wall-plug efficiency and a significantly simplified thermal footprint compared to gas or lamp-pumped alternatives. The laser source, drive electronics, and thermal management are integrated into a single compact platform, with active closed-loop stabilization maintaining output power within  $\pm 1\%$  RMS across the full operating temperature range.



## Applications

- Advanced research
- Laser light show
- RGB mixing laser systems

## Key Feature Highlights

• <b>Compact, Integration-Ready Design</b>	Fits standard optical breadboards and cage systems; Compact design enables direct drop-in to instrument assemblies
• <b>Stable Output (<math>\pm 1\%</math> RMS)</b>	Active closed-loop control ensures consistent power across the full operating range
• <b>30 kHz TTL/Analog Modulation</b>	Hardware-level synchronization with cameras, lock-in amplifiers, and instrument timing systems
• <b>Efficient Thermal Management</b>	Low thermal load and passive heat dissipation reduce the need for active cooling, simplifying optical table layouts
• <b>Long Operational Lifetime</b>	Semiconductor gain medium with no consumables, no gas fill, and no electrodes — operate without scheduled maintenance interventions



# Technical Specification

## OPTICAL PARAMETERS

Center Wavelength	445 nm ± 5 nm
Operating Mode	Continuous Wave
Output Power	1 – 500 mW
Power Stability (rms, 4 hours±3°C)	< 1%
Transverse Mode	Multimode
Beam Divergence (full angle)	< 2.1 x 1.6 mrad
Beam Diameter at the aperture (1/e <sup>2</sup> )	~ 2.5 mm x 5.2 mm
Polarization Ratio	> 50:1 (> 100:1 optional)

## ELECTRICAL PARAMETERS

Compatible Power Supply	85 – 264 VAC	LPS-I/LPS-II (frequency range from 1Hz – 30kHz)
	100 – 240 VAC	LPS-III (frequency range from 30kHz – 100kHz)
Modulation Options	1Hz-1kHz, 1kHz-10kHz, 10kHz-30kHz, 30kHz-100kHz optional, TTL/Analog optional	

## MECHANICAL PARAMETERS

Dimensions	143.5(L) × 73(W) × 46.2(H) mm <sup>3</sup>
Weight	0.7 kg
Cooling Method	Conduction
Beam Height from Base Plate	24.8 mm

## ENVIRONMENTAL

Operating Temperature	10 – 35 °C
Laser Warmup Time	< 5 min
Expected Lifetime	> 10,000 hours

# Mechanical Drawings

## Laser Head

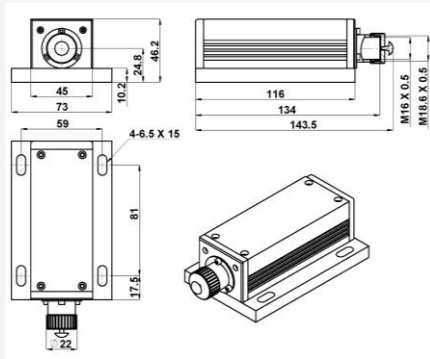

143.5(L) × 73(W) × 46.2(H) mm<sup>3</sup>, 0.7kg

## Compatible Power Supply (LPS-I)

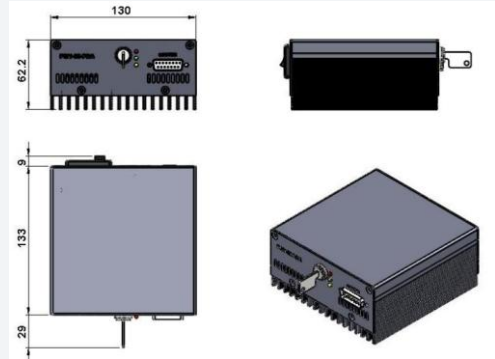

171(L) × 130(W) × 62.2(H) mm<sup>3</sup>, 1.2kg

## Compatible Power Supply (LPS-II)

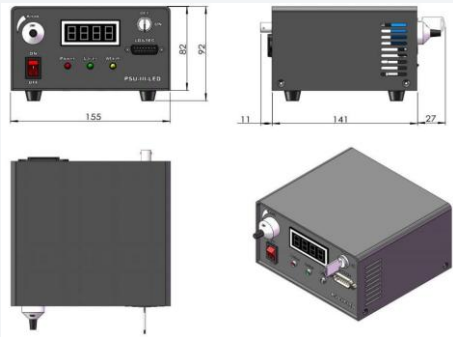

179(L) × 155(W) × 92(H) mm<sup>3</sup>, 1.5kg

## Compatible Power Supply (LPS-III)



162(L) × 144(W) × 70(H) mm<sup>3</sup>, 1.0kg

## Product Certifications

